

Preinstallation Manual
DIAMOND™ Series OEM/Industrial
DIAMOND™ C-40 Liquid-Cooled Laser

Preinstallation Manual
DIAMOND™ Series OEM/Industrial
DIAMOND™ C-40 Liquid-Cooled Laser

This document is copyrighted with all rights reserved. Under copyright laws, this document may not be copied in whole or in part, or reproduced in any other media, without the express written permission of Coherent, Inc. (Coherent). Permitted copies must carry the same proprietary and copyright notices as were affixed to the original. This exception does not allow copies—whether or not sold—to be made for others; however, all the material purchased may be sold, given, or loaned to another person. Under the law, “copying” includes translation into another language.

Coherent, the Coherent Logo, DIAMOND, and FieldMax are trademarks or registered trademarks of Coherent, Inc. All other trademarks or registered trademarks are the property of their respective owners.

Patents referenced in this manual are active when the manual is printed (see last page for date). You are advised to check to see if the patents are still active <http://portal.uspto.gov/external/portal/pair>.

Every effort has been made to ensure that the data given in this document is accurate. The information, figures, tables, specifications, part numbers, and schematics contained herein are subject to change without notice. Coherent makes no warranty or representation, either expressed or implied, with respect to this document. In no event will Coherent be liable for any direct, indirect, special, incidental, or consequential damages resulting from any defects in its documentation.

Technical Support

In the U.S.:

Should you experience any difficulties with your laser or need any technical information, please visit our Web site www.Coherent.com. Should you need further assistance, please contact Coherent Technical Support via e-mail Product.Support@Coherent.com or telephone, 1-800-367-7890 (1-408-764-4557 outside the U.S.). Please be ready to provide model and laser head serial number of your laser system as well as the description of the problem and any corrective steps attempted to the support engineer responding to your request.

Telephone coverage is available Monday through Friday (except U.S. holidays and company shutdowns). Inquiries received outside normal office hours will be documented by our automatic answering system and will be promptly returned the next business day.

Outside the U.S.:

If you are located outside the U.S., please visit www.Coherent.com for technical assistance, or phone your local Service Representative. Service Representative phone numbers and addresses can be found on the Coherent web site.

Coherent provides telephone and web-based technical assistance as a service to its customers and assumes no liability thereby for any injury or damage that may occur contemporaneous with such services. Under no circumstances do these support services affect the terms of any warranty agreement between Coherent and the buyer. Operation of any Coherent laser with any of its interlocks defeated is always at the operator's own risk.

TABLE OF CONTENTS

Signal Words and Symbols in this Manual.....	v
Signal Words.....	v
Symbols	v
Preface	vii
Export Control Laws Compliance	vii
Notice Concerning Regulatory Status of DIAMOND Series Lasers.....	viii
Notice Concerning Warranty	viii
Section One: Description and Specifications.....	1-1
Introduction.....	1-1
Purpose of This Manual.....	1-1
Specifications and Input Requirements	1-2
Hardware Overview	1-2
DC Input Power	1-2
Cooling Requirements	1-2
Comparison of Air Cooling and Liquid Cooling (Reference)	1-3
Liquid-Cooling Option of DIAMOND C-40.....	1-3
Laser Head	1-4
RF Power Module.....	1-4
Specifications.....	1-4
Section Two: Laser Safety	2-1
Optical Safety	2-1
Viewing Distance.....	2-2
Electrical Safety.....	2-4
Laser Head	2-4
Laser Safety Requirements	2-5
Safety Interlocks	2-6
Compliance to Standards Relevant to CE Mark	2-6
Environmental Compliance	2-7
Waste Electrical and Electronic Equipment (WEEE, 2002).....	2-7
Location of Safety Labels	2-8
Section Three: Utility Requirements and System Installation.....	3-1
Introduction.....	3-1
Unpacking and Inspection	3-1
Verifying Delivery	3-1
Checking Delivered Items	3-1
Safety Issues in Laser Installation	3-2
Mechanical Mounting.....	3-2
Mounting Considerations for DIAMOND C-40.....	3-4
Liquid Cooling.....	3-5
Cooling System Layout	3-5

Re-Circulation and Coolant Flow Interlock Switch	3-6
Signal Interface	3-6
Thermal Shutdown Switch.....	3-6
DC Power Relay	3-6
Condensation of Water Vapor	3-7
Coolant Fittings on Laser System.....	3-8
Cooling Capacity	3-8
Coolant Filtering	3-9
Coolant Flow Rate and Pressure.....	3-9
Pressure Drop.....	3-9
Electrical Power Connection	3-10
DC Power Supply Requirements	3-11
DC Power Supply Cabling Requirements	3-11
DC Power Supply Over-Voltage Tripping	3-12
Control Signal Connection.....	3-12
Beam Propagation.....	3-13

LIST OF ILLUSTRATIONS

1-1.	DIAMOND C-40 Liquid-Cooled Laser.....	1-1
1-2.	Cooling System Diagram.....	1-3
2-1.	Nominal Ocular Hazard Distance (NOHD) for indicated conditions calculated per ANSI Z136.1-2007	2-2
2-2.	Hazardous Substance Table & Environment-Friendly Use Period (EFUP)	2-7
2-3.	Waste Electrical and Electronic Equipment Label	2-7
2-4.	Location of Safety Labels	2-8
3-1.	DIAMOND C-40 Liquid-Cooled Laser Head Dimensions	3-3
3-2.	Recommended Liquid Cooling System Functional Block Diagram	3-5
3-3.	DIAMOND C-40 Liquid Cooling Connections.....	3-8
3-4.	Electrical Connections to DIAMOND C-40.....	3-10
3-5.	Beam Diameter vs. Distance from Laser Head.....	3-13

LIST OF TABLES

1-1.	Comparison: The Benefits of Air-Cooling vs. Liquid-Cooling Methods.....	1-3
1-2.	Specifications and Input Requirements for DIAMOND C-40 Lasers	1-5

Signal Words and Symbols in this Manual

This documentation may contain sections in which particular hazards are defined or special attention is drawn to particular conditions. These sections are indicated with signal words in accordance with ANSI Z-535.6 and safety symbols (pictorial hazard alerts) in accordance with ANSI Z-535.3 and ISO 7010.

Signal Words

Four signal words are used in this documentation: **DANGER**, **WARNING**, **CAUTION** and **NOTICE**.

The signal words **DANGER**, **WARNING** and **CAUTION** designate the degree or level of hazard when there is the risk of injury:

DANGER!

Indicates a hazardous situation that, if not avoided, will result in death or serious injury. This signal word is to be limited to the most extreme situations.

WARNING!

Indicates a hazardous situation that, if not avoided, could result in death or serious injury.

CAUTION!

Indicates a hazardous situation that, if not avoided, could result in minor or moderate injury.

The signal word “**NOTICE**” is used when there is the risk of property damage:

NOTICE!

Indicates information considered important, but not hazard-related.

Messages relating to hazards that could result in both personal injury and property damage are considered safety messages and not property damage messages.

Symbols

The signal words **DANGER**, **WARNING**, and **CAUTION** are always emphasized with a safety symbol that indicates a special hazard, regardless of the hazard level:



This symbol is intended to alert the operator to the presence of important operating and maintenance instructions.



This symbol is intended to alert the operator to the danger of exposure to hazardous visible and invisible laser radiation.



This symbol is intended to alert the operator to the presence of dangerous voltages within the product enclosure that may be of sufficient magnitude to constitute a risk of electric shock.



This symbol is intended to alert the operator to the danger of Electro-Static Discharge (ESD) susceptibility.



This symbol is intended to alert the operator to the danger of crushing injury.



This symbol is intended to alert the operator to the danger of a lifting hazard.

Preface

This is the Preinstallation Manual for the DIAMOND C-40™ Liquid-Cooled OEM/Industrial carbon dioxide (CO₂) lasers manufactured by Coherent. These lasers are OEM systems, they are designed as components which are to be inserted by the original equipment manufacturer (OEM) prior to delivery to the end user. Coherent strongly recommends that the user read Section Two: Laser Safety, before operating the laser.



WARNING!

Use of controls or adjustments or performance of procedures other than those specified in this manual may result in hazardous radiation exposure.

Export Control Laws Compliance

It is the policy of Coherent to comply strictly with U.S. export control laws.

Export and re-export of lasers manufactured by Coherent are subject to U.S. Export Administration Regulations, which are administered by the Commerce Department. In addition, shipments of certain components are regulated by the State Department under the International Traffic in Arms Regulations.

The applicable restrictions vary depending on the specific product involved and its destination. In some cases, U.S. law requires that U.S. Government approval be obtained prior to resale, export or re-export of certain articles. When there is uncertainty about the obligations imposed by U.S. law, clarification must be obtained from Coherent or an appropriate U.S. Government agency.

Products manufactured in the European Union, Singapore, Malaysia, Thailand: These commodities, technology, or software are subject to local export regulations and local laws. Diversion contrary to local law is prohibited. The use, sale, re-export, or re-transfer directly or indirectly in any prohibited activities are strictly prohibited.

**Notice
Concerning
Regulatory
Status of
DIAMOND
Series Lasers**

This laser component does not include all safety features that are required by the United States Food and Drug Administration (FDA), Center for Devices and Radiological Health (CDRH) in laser systems sold to end users. It is sold solely to qualified manufacturers who in their end product, supply interlocks, indicators, and other required safety features, in full compliance with 21 CFR 1040, Subchapter J and/or other applicable national and local regulations.

**Notice
Concerning
Warranty**

Operation or handling of this laser component, inconsistent with this manual, may void the warranty.

SECTION ONE: DESCRIPTION AND SPECIFICATIONS

Introduction

This section details specifications and characteristics (including mechanical, thermal, electrical, and optical interfaces; environmental requirements, and limitations) of the DIAMOND C-40 laser.

The DIAMOND C-40 laser is a sealed-off, RF excited CO₂ laser, capable of continuous wave (CW) or modulated operation. From the laser safety point of view, this laser is considered to be a component and must be integrated into a system by a qualified original equipment manufacturer (OEM) prior to delivery to the end user. See the section titled “Laser Safety Requirements” on page 2-5 for a complete discussion of laser safety issues.

Purpose of This Manual

This manual is designed to assist the original equipment manufacturer (OEM) during the integration of the DIAMOND C-40 OEM laser. It contains information about the performance and operation of the laser as well as installation and control methods.



Figure 1-1. DIAMOND C-40 Liquid-Cooled Laser

Specifications and Input Requirements

Table 1-2 on page 1-5 provides specifications and requirements for cooling water and power inputs for the DIAMOND C-40 laser.

Figure 1-1 on page 1-1 illustrates the baseline configurations (i.e., without any optional hardware additions or deletions) of the DIAMOND C-40 laser. Each laser system consists of a laser head assembly and an integrated radio frequency (RF) power module. The RF power module converts 48 VDC, ≤ 13 A (20 A peak for 1 ms) power to radio frequency power.

Connection of the customer-supplied DC power supply to the DIAMOND C-40 is via a barrier strip with screw terminals on the RF power module. These terminals should also be used for the connection of wires for remote voltage sensing. Such sensing is recommended to control the voltage at the input to the RF power module more precisely.

Hardware Overview

The DIAMOND C-40 laser is a waveguide, carbon dioxide (CO₂) laser. RF electric fields provided by the RF power module excite the CO₂ gas mixture. The standard configuration of this laser operates at a wavelength near 10.6 μm in the infrared region of the electromagnetic spectrum.

DC Input Power

DC input power is provided by the user through customer-supplied bus wiring, which goes to the RF power module. The RF power module converts this DC electrical power into RF power which is used to excite the gas in the laser head. The DC power supply requirements are discussed in detail in the subsection titled, “DC Power Supply Requirements” on page 3-11.

Cooling Requirements

Total heat dissipation for the laser is specified in Table 1-2 on page 1-5. The laser head typically dissipates 400 W from its base surface while the RF power module typically dissipates 200 W, for a total typical heat dissipation of 600 W (maximum total heat dissipation is 695 W). The DIAMOND C-40 must be provided adequate cooling to keep the laser operating temperature within acceptable limits. The cooling method that is used must not induce stresses that will result in misalignment of the laser resonator. The DIAMOND C-40 heat sinks are designed so the assembled structure remains free of excessive stress.

Comparison of Air Cooling and Liquid Cooling (Reference)

Air cooling and liquid cooling each have distinct advantages. Table 1-1 describes the factors that should be taken into consideration when choosing a cooling system for a laser module.

Consideration should also be taken if condensable vapors are present and to take suitable measures to purge sensitive areas, such as optical surfaces, with a suitable gas.

Table 1-1. Comparison: The Benefits of Air-Cooling vs. Liquid-Cooling Methods

AIR COOLING	LIQUID COOLING
<ul style="list-style-type: none"> • Low in cost • Low in complexity • Low service requirements • Easier to install 	<ul style="list-style-type: none"> • Offers the highest process stability • Can yield the most compact arrangement • Suitable for applications in which the ambient air temperature exceeds 40°C • Better for applications in which the ambient air is laden with particulates • Easier to make a hermetically sealed system

Liquid-Cooling Option of DIAMOND C-40

Installation requirements related to the liquid-cooling option of the DIAMOND C-40 laser are discussed in detail in Section 3, “Liquid Cooling”, on page 3-5. This section is a quick overview only. Figure 1-2 shows the recommended connection from the customer-supplied refrigerated recirculator to the DIAMOND C-40 laser system.

Coherent recommends that the coolant water flowing from the customer-supplied refrigerated recirculator flow to the laser head, then to the RF power module. Although not shown in Figure 1-2, a flow interlock device must be provided by the customer in the cooling-water-return line to detect the presence of cooling water with the required flow rate, and to shut down the laser if adequate coolant flow is not present.

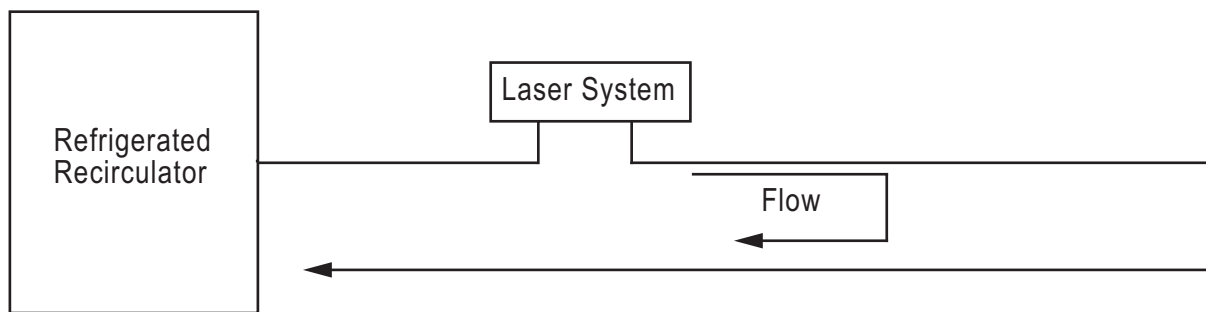

Figure 1-2. Cooling System Diagram



NOTICE!

To avoid damage to the laser, never operate the laser without a supply of cooling water meeting the requirements indicated in Table 1-2.

Laser Head

The laser head takes RF input power and converts some of it to laser radiation. The rest of the RF input power is exhausted as waste heat. For the DIAMOND C-40 liquid-cooled laser, this waste heat is exhausted into the liquid cooling water which flows through the laser head. The laser head consists of the folded optical waveguide resonator, the all-metal gas envelope structure, and RF power module. Infrared laser radiation is emitted from the optical aperture. Pictures and dimensions drawings for the DIAMOND C-40 liquid-cooled laser are shown in Figure 1-1 and Figure 3-1 on page 3-3.

RF Power Module

The DIAMOND C-40 RF power module converts DC input power to RF energy, which is sent to the laser head. Heat from the RF power module flows into the integrated laser assembly and is exhausted into the liquid cooling water. An RJ-45-type connector is used to control the laser system. All of the user interfaces (DC power, cooling water, and signal interface) are on one panel of the RF power module.

Specifications

Table 1-2 describes the specifications and input requirements for DIAMOND C-40 lasers.

Table 1-2. Specifications and Input Requirements for DIAMOND C-40 Lasers

SYSTEM PERFORMANCE SPECIFICATIONS	Wavelength	10.55 μ m to 10.65 μ m
	Optical Output Power ¹	40 W
	Power Stability ²	$\pm 5\%$
	Mode Quality	$M^2 < 1.3$
	Beam Size	3.6 \pm 0.5 mm @ output aperture
	Beam Divergence	< 5.0 mRad, full angle
	Polarization	> 100 to 1 (Fixed linear, parallel to width dimension)
	Operating Frequency & Duty Cycle	0 to 25 kHz, 0 to 100% DC
CONFIGURATION & FACILITY REQUIREMENTS	Weight	6.4 kg (14.0 lbs.)
	Dimensions L x W x H	460.8 x 92.5 x 104.1 mm (18.15 x 3.64 x 4.1 in.)
	Input voltage	48 VDC $\pm 2\%$ regulation, < $\pm 1\%$ P-P Noise/Ripple 13 A with 20 A peak for 1 mS minimum, measured at input terminals
	Heat Dissipation	< 695 W
	Coolant	Distilled Water w/ 25 to 35% Dow Frost*
	Cooling Flow Rate	> 3.8 lpm (1.0 gpm)
	Maximum Coolant Pressure	6.9 bar (100 psig)
	Max. Pressure Differential (@1.0 gpm)	1.5 bar (22 psig)
	Coolant Temperature	15°C to 30°C (59°F to 86°F)
	Maximum Case Temperature	< 60°C (140°F)
	Operating Environment - Temperature	5°C to 55°C (41°F to 131°F)
	Altitude	< 2,000 m (6,500 ft.)
	Humidity	Non-condensing
	Shipping/Storage Environment	- 10°C to 60°C (14°F to 140°F), Non-condensing
¹ Power measured @ 25°C & derated by 1%/°C for higher laser head temperatures ² Power Stability based on $\pm (P_{max}-P_{min})/(2*P_{max})$ average power measurement @ constant duty cycle after 10-minute warm-up @ operating condition *DOWFROST is a trademark of the Dow Chemical Company		

SECTION TWO: LASER SAFETY

Optical Safety

The DIAMOND C-40 laser has undergone extensive testing to ensure that, with proper usage, it is a safe and reliable device.

Because of its special properties, laser light poses safety hazards not associated with light from other sources. The safe use of lasers requires that all laser users and everyone near a laser be aware of the dangers involved in laser operation.



WARNING!

Direct eye contact with the output beam from the laser will cause serious damage and may cause blindness.

Viewing Distance

The C-40 lasers produce optical power levels that are dangerous to the eyes and skin if exposed directly or indirectly. These products must be operated only with proper eye and skin protection at all times. Never view directly emitted or scattered radiation with unprotected eyes. When viewing the laser during operation, the operator must maintain the Nominal Ocular Hazard Distance (NOHD) between the laser or scattered radiation and the operator's eyes. Figure 2-1 summarizes the NOHD for the power range of the C40 for direct viewing of the collimated beam along with two other common configurations. The NOHD in this figure is based on the Maximum Permissible Exposure (MPE = 0.1 W/cm²) level for each power condition as specified in ANSI Z136.1-2007 and IEC 60825-1-2007 (Rule 2 applies over nearly all of the operating range of this laser).

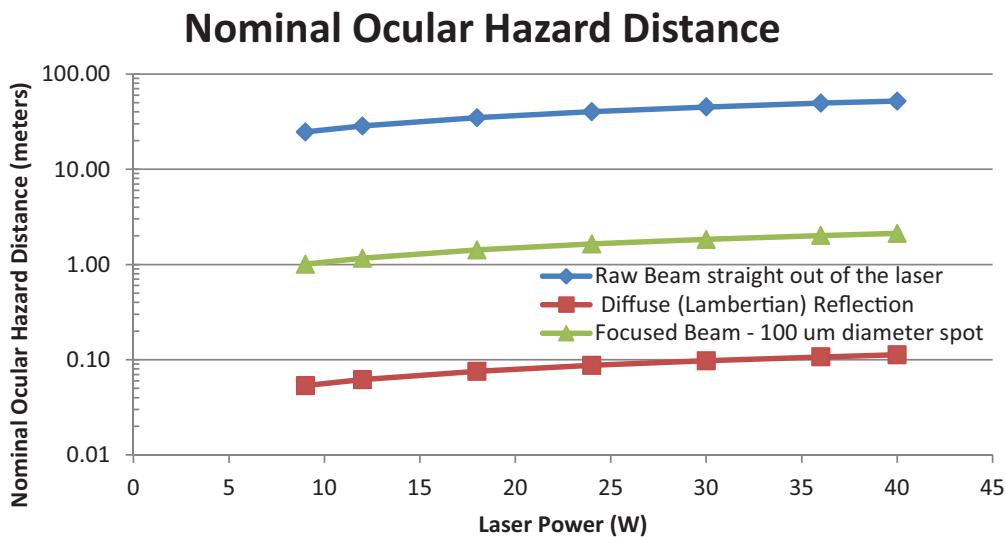

Figure 2-1. Nominal Ocular Hazard Distance (NOHD) for indicated conditions calculated per ANSI Z136.1-2007

All personnel in the same room as the laser or anyone who may be exposed to the laser beam should be informed that a laser is in operation. All personnel must wear laser safety glasses which protect against the wavelengths in use.



WARNING!

There is no visible indication at the DIAMOND C-40 laser head that it is operating. Use extreme care when working around or near the laser output to avoid hazardous radiation exposure. Failure to do so could result in serious injury.



CAUTION!

Exercise caution to protect against specular reflections since reflections at the DIAMOND C-40 laser wavelength are invisible. These reflections, while weaker than the main beam, may be sufficiently intense to cause eye damage.

Eye safety is a great concern when using a high-power laser such as the DIAMOND C-40 laser. There are often many secondary beams present at various angles near the laser. These beams are specular reflections of the main beam from polished surfaces. While weaker than the main beam, such beams may still be sufficiently intense to cause eye damage.

Laser beams are also powerful enough to burn skin, clothing or paint. They can ignite volatile substances such as alcohol, gasoline, ether, and other solvents and can damage the light-sensitive elements in video cameras, photomultipliers, and photodiodes.

Coherent provides the following recommendations to promote the safe use of the DIAMOND C-40 laser. Operators are advised to adhere to these recommendations and employ sound laser safety practices at all times.

- Use protective eyewear when operating the laser and guard against inadvertent exposure to skin or clothing. Select eyewear which is suitable for use with the wavelengths and radiation intensity that the laser emits. Refer to the *Guide for Selection of Laser Eye Protection*, Laser Institute of America (6th Edition), 2007.
- The beam path should be enclosed with a protective cover (ideally with an interlock scheme) and these covers should not be removed during normal use.
- Never look directly into the laser output port when the power is on.
- Set up the laser and all optical components used with the laser away from eye level. Provide enclosures for the laser beam.
- Use the laser in a room with access controlled by door interlocks. Post warning signs. When operating the laser, limit access to the area to individuals who are trained in laser safety.
- Avoid operating the laser in a darkened environment.
- Do not use the laser in the presence of flammables, explosives, or volatile solvents such as alcohol, gasoline, or ether.

For additional information on laser safety, refer to the following publications:

- *American National Standard for the Safe Use of Lasers*, Z136.1-2007, American National Standards Institute, 2007.
- *Performance Standard for Laser Products*, United States Code of Federal Regulations, 21CFR1040 10(d).
- *Laser Safety Guide*, Laser Institute of America. (11th Edition). Orlando, FL 2007.
- *Guide for Selection of Laser Eye Protection*, Laser Institute of America (6th Edition), 2007.
- D. Sliney and M. Wolbarsht. *Safety with Lasers and Other Optical Sources*,. Plenum Publishing Company, New York, N.Y., 1980.

Many of these documents on Laser Safety are available through Laser Institute of America, 13501 Ingenuity Drive, Suite 128, Orlando, CA 32826. Phone 800-345-2737 and on their website www.lia.org.

Electrical Safety

The DIAMOND C-40 RF power module requires only 48 VDC input voltage. This voltage and other voltages derived within this laser can be lethal. Every portion of the electrical system should be treated as if it is at a dangerous voltage level.



DANGER!

To avoid potentially fatal electrical shock hazards from electrical equipment, follow all applicable electrical codes such as (in the U.S.) the National Electrical Code.

Laser Head

High voltages are present in the laser head when the power is on. There are no serviceable parts or optics within the laser head. Do not remove any covers or make any adjustments to any screw.



DANGER!

To avoid potentially fatal electrical shock hazards from electrical equipment, follow all applicable electrical codes such as (in the U.S.) the National Electrical Code.

Laser Safety Requirements

This laser does not conform to the United States or Foreign Government requirements for laser safety. In the United States, it is the responsibility of the Buyer to ensure that the product sold to the end user complies with all laser safety requirements prior to resell. These laser safety requirements are contained in 21 CFR, Sub Chapter J and are administered by the Center for Devices and Radiological Health (CDRH).

The text of this federal law is available from the U.S. Government Printing Office Bookstore located in most major cities in the U.S. as well as Washington, D.C. A report detailing how the laser product complies with the Federal law is required before the product is shipped. The form of this report is covered in a pamphlet entitled: *Guide for Preparing Product Reports for Lasers and Products Containing Lasers*, Sept. 1995:

U.S. Department of Health and Human Services
Public Health Service
Food and Drug Administration
Center for Devices and Radiological Health
Division of Small Manufactures Assistance
Rockville, Md 20857
Voice phone: 1-800-638-2041
Web site: <http://www.fda.gov/cdrh>

For jurisdictions outside of the United States, it is the responsibility of the Buyer of this laser device to ensure that it meets the local laser safety requirements. Additional regulatory information is available at the CDRH web site www.fda.gov/cdrh.

Safety Interlocks

The RF power module and laser head covers are not interlocked. These covers should never be removed. There are no user serviceable components inside.



DANGER!

To avoid potentially fatal electrical shock hazards from electrical equipment, follow all applicable electrical codes such as (in the U.S.) the National Electrical Code.



WARNING!

Use of controls or adjustments, or performance of procedures other than those specified herein, may result in hazardous radiation exposure.

Compliance to Standards Relevant to CE Mark

The DIAMOND C-40 lasers are OEM products, and are sold as components for integration into complete laser systems by a system integrator. These products are tested and CE Marked as independent products. For specific details regarding what applicable compliance directives and standards the products have been tested to, please refer to the Declaration of Conformity which is available upon request from Coherent, per contact information on page ii of this manual.

Compliance to applicable standards for a particular laser tool incorporating DIAMOND C-40 lasers must be demonstrated by the manufacturer of the complete system. The primary issue for the system integrator is to design covers, shielding, grounding, routing of electrical cable assemblies, and control elements with the proper safety features so that during subsequent testing the system meets the appropriate standards.

Coherent recommends the following guidelines to control the amount of radiated interference:

- Use high quality cables and connectors for all electrical connections
- Verify grounding of cable shields, generally at both ends of the cable

Environmental Compliance

1. The DIAMOND C-40 complies with European Union Directive 2002/95/EC Restriction of Hazardous Substances. Upon request, Coherent Technical Support will supply a materials declaration (please specify Coherent Part/Item Number).
2. The DIAMOND C-40 complies with the China Ministry of Information Order #39: Management Methods for Controlling Pollution by Electronic Information Products. Refer to Figure 2-2.

铅	汞	镉	六价铬	多溴联苯	多溴二苯醚	
Pb	Hg	Cd	Cr6 ⁺	PBB	PBDE	
X	O	O	O	O	O	
O≡小于最高浓度值 X≡大于最高浓度值						

Figure 2-2. Hazardous Substance Table & Environment-Friendly Use Period (EFUP)

Waste Electrical and Electronic Equipment (WEEE, 2002)

The European Waste Electrical and Electronic Equipment (WEEE) Directive (2002/96/EC) is represented by a crossed-out garbage container label (see Figure 2-3). The purpose of this directive is to minimize the disposal of WEEE as unsorted municipal waste and to facilitate its separate collection.

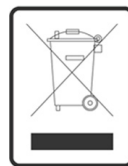
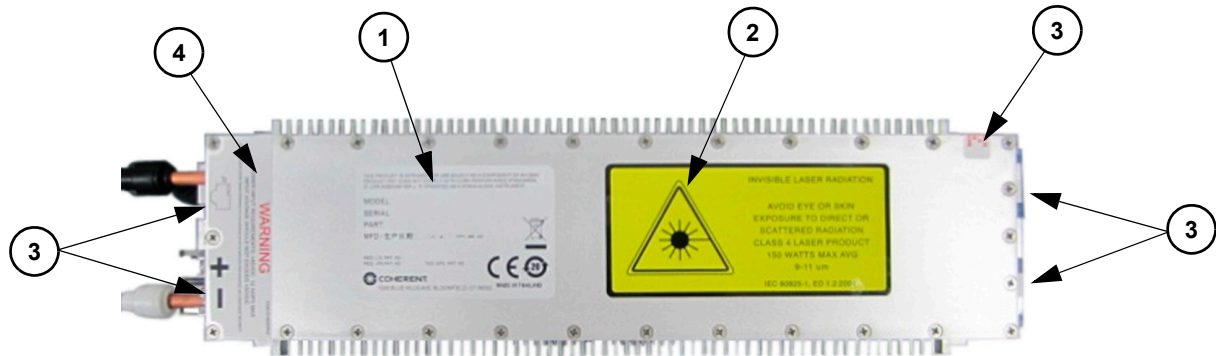

Figure 2-3. Waste Electrical and Electronic Equipment Label

Location of Safety Labels

Refer to Figure 2-4 for a description and location of all required safety labels. These include warning labels indicating removable or displaceable protective housings, apertures through which laser radiation is emitted and labels of certification and identification [CFR 1040.10(g), CFR 1040.2, and CFR 1010.3/EN60825-1, Clause 5].



TOP VIEW

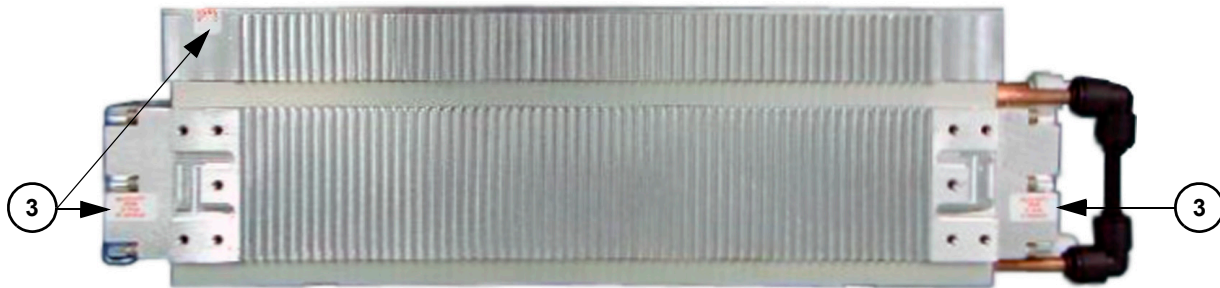
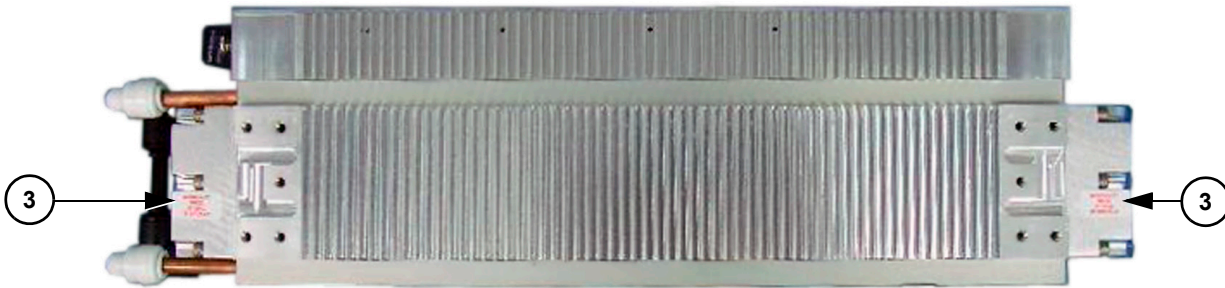

SIDE VIEWS

Figure 2-4. Location of Safety Labels (Sheet 1 of 4)

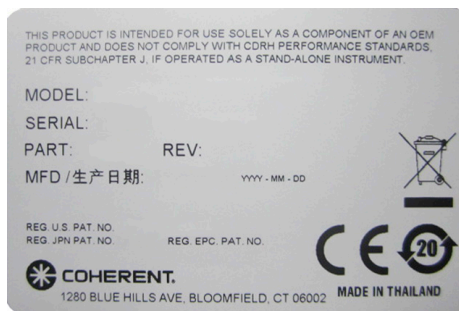
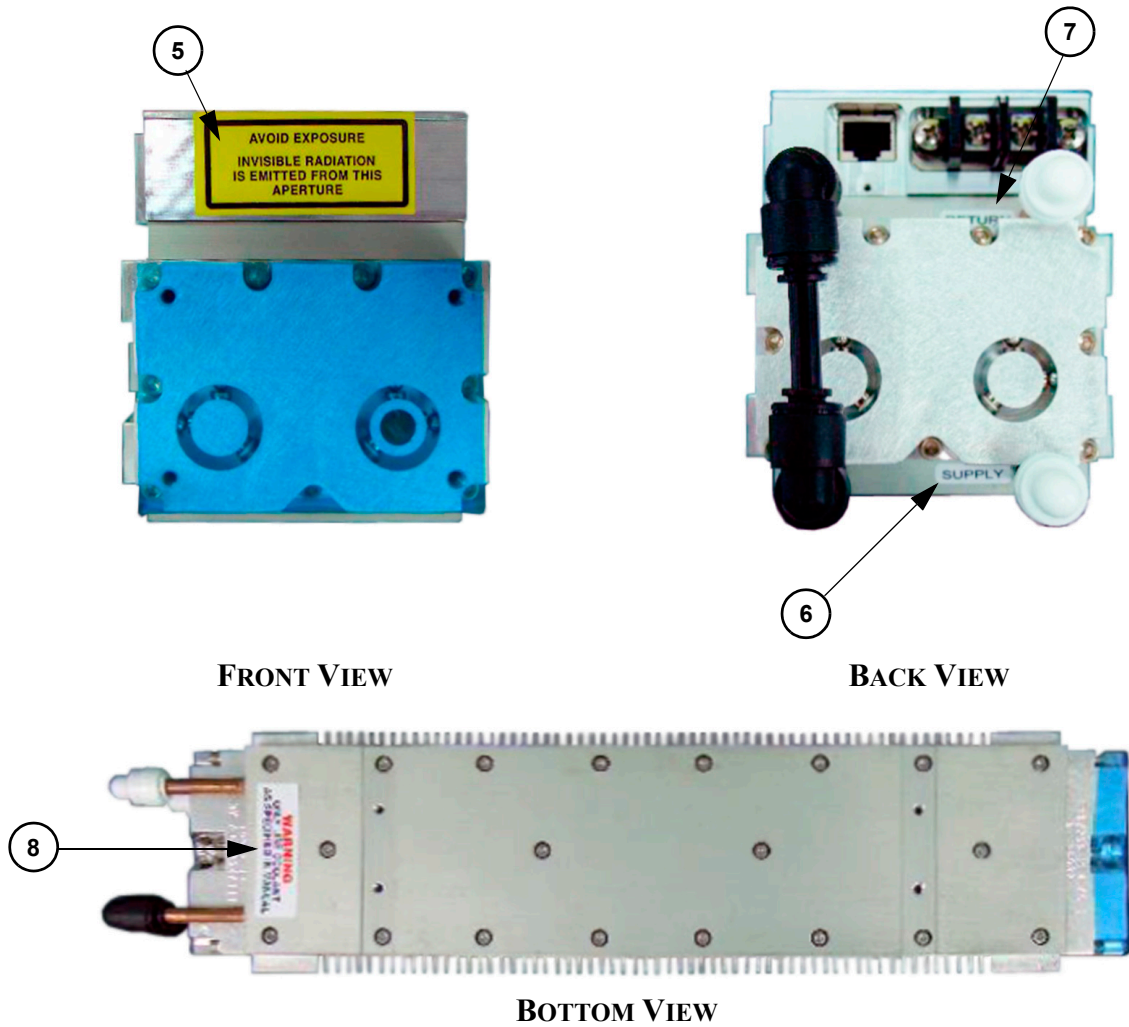

1. IDENTIFICATION LABEL

Figure 2-4. Location of Safety Labels (Sheet 2 of 4)

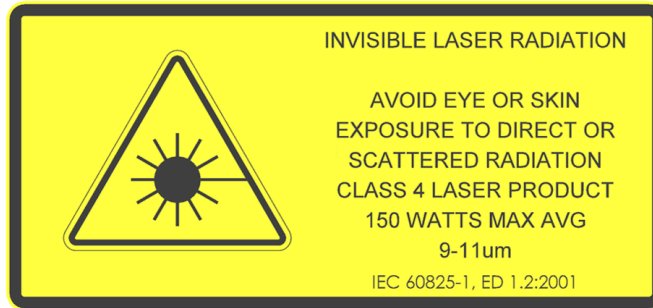

2. DANGER OF LASER RADIATION LABEL



3. TAMPER PROOF LABEL



4. VOLTAGE WARNING LABEL



5. WARNING APERTURE LABEL



6. COOLANT SUPPLY LABEL

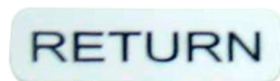

7. COOLANT RETURN LABEL

Figure 2-4. Location of Safety Labels (Sheet 3 of 4)



8. COOLANT WARNING

Figure 2-4. Location of Safety Labels (Sheet 4 of 4)

SECTION THREE: UTILITY REQUIREMENTS AND SYSTEM INSTALLATION

Introduction

This section covers unpacking and installation of the DIAMOND C-40 laser. Specific operating instructions are detailed in Section Four: Laser Operation.

Unpacking and Inspection

Before unpacking the laser components, inspect the shipping carton for evidence of rough handling, and note any damage. If damage to the shipping carton is evident, request that the carrier's agent be present when the unit is unpacked. Inform the shipping carrier and Coherent of any evidence of damage in shipment. The Buyer and shipping carrier is responsible for any damage which might occur during shipment.

Verifying Delivery

The shipping container contains the following:

- Laser head and integral RF power module
- Final test sheet
- This Operating Manual

If any of these items are missing, report this to Coherent immediately.

Checking Delivered Items

Verify that the delivered laser head model received is the one ordered. If there is any discrepancy found, contact Coherent immediately.

Coherent recommends that the shipping box and packing materials be saved, as these will be required should the laser need to be shipped back to the factory.

Safety Issues in Laser Installation

Installation of the DIAMOND C-40 laser must comply with all applicable electrical safety and laser safety laws and regulations. Review Section Two: Laser Safety for important information relating to safety.

The negative (return) side of the DC input connection to the DIAMOND C-40 RF power module is connected internally to the chassis. The user must ensure that the system into which the DIAMOND C-40 is built protects against the possibility that the DIAMOND C-40 laser head or RF power module chassis could be at a hazardous voltage and that personnel could be exposed to these voltages.



DANGER!

To avoid potentially fatal electrical shock hazards from electrical equipment, follow all applicable electrical codes such as (in the U.S.) the National Electrical Code.

The laser must be secured properly to avoid the possibility of the laser shifting unexpectedly during operation, creating a hazardous condition. The location of the output beam of the DIAMOND C-40 laser head is shown in Figure 3-1. The laser output is emitted from the aperture shown in the referenced figures and propagates within a full cone angle up to 5°. The acceptance angle of the system aperture must intercept all of the output of the laser.

It is also extremely important to understand the direction, divergence, and magnitude of all reflections that will occur from optical surfaces. Infrared (IR) beams, such as those from DIAMOND C-40 lasers, can also be located with commercially available IR screens, such as those produced by Macken Instruments, Inc. [tel. (707) 566-2110]. Coherent recommends that all beam propagation paths be enclosed and that personnel operating the laser be qualified optical technicians who are familiar with this type of hardware.

Mechanical Mounting

The dimensions for the DIAMOND C-40 laser head is shown in Figure 3-1. Mechanical mounting of the DIAMOND C-40 laser head must result in no distortion or stress the laser head is in any way. Otherwise, optical alignment and power stability could be adversely affected.

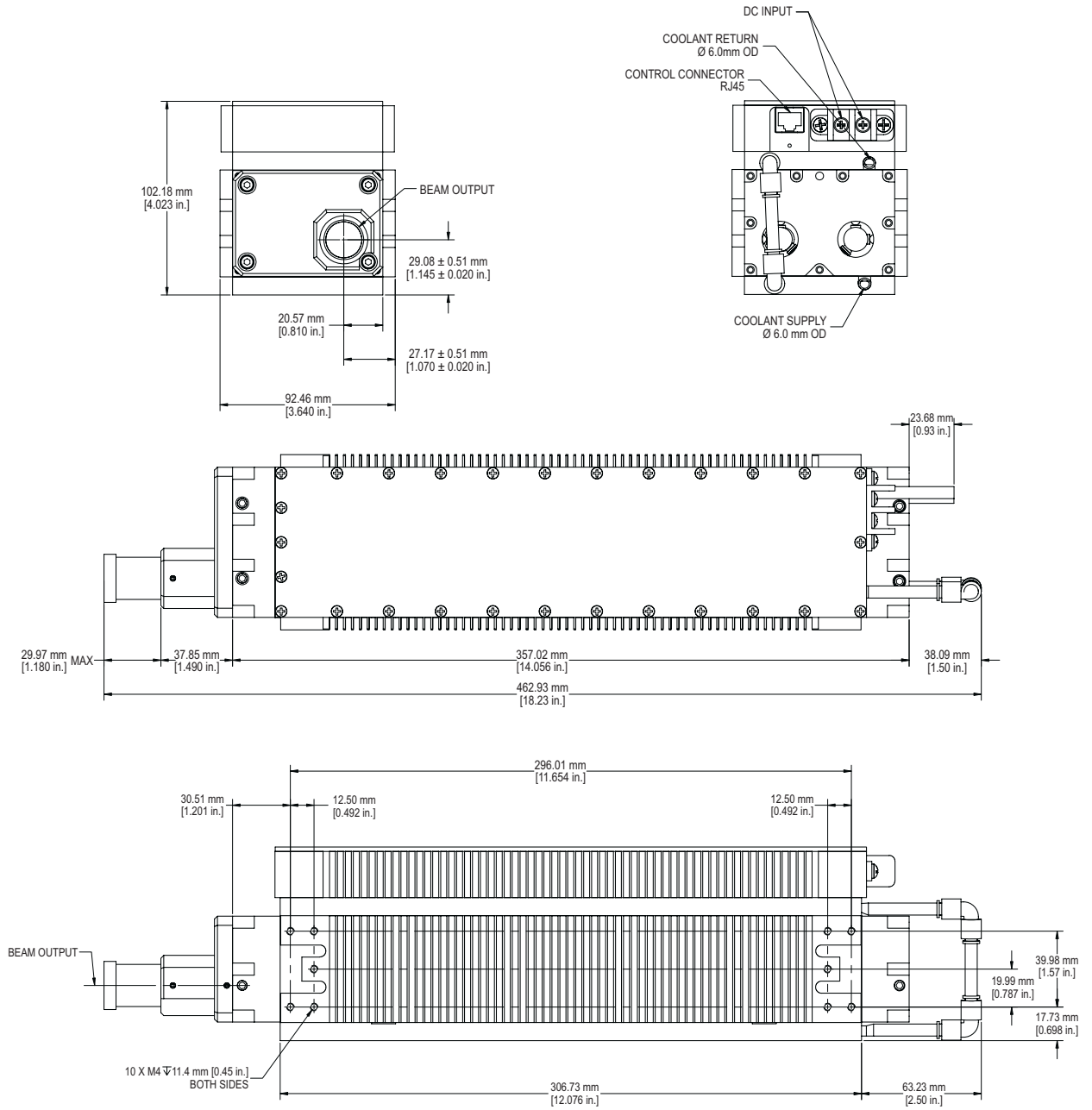

Figure 3-1. DIAMOND C-40 Liquid-Cooled Laser Head Dimensions

Mounting Considerations for DIAMOND C-40

Certain aspects of specific customer applications may preclude absolute interchangeability of laser heads. For example, for certain applications, the sensitivity of the application to optical beam pointing errors may require external optical realignment after the laser head is replaced in the customer's integrated system. Depending on the method of mounting and the sensitivity of the integrated customer system to beam pointing errors, even removing a laser head from the customer's system, then replacing the same laser head back into the customer's system may require external optical realignment. This external alignment would be a repositioning of the head itself or adjustment of beam delivery mirrors (positions and angle). Consult Coherent if there is any question about such interchangeability issues.

Coherent recommends using optional brackets (part number 1101-12-0016 for a set of 4) that are designed for mounting the laser safely without inducing any stress onto the laser. Care must be taken not to induce stress onto the laser head, as optical mis-alignment of the laser resonator can occur that would require the laser to be returned to Coherent for service. A mechanical drawing for this bracket is provided in the Appendix A. Coherent strongly encourages use of this bracket or one of similar design in order to accommodate the temperature changes in operation while providing secure mounting.

Liquid Cooling

The DIAMOND C-40 liquid-cooled laser is cooled by means of liquid coolant. The cooling system external to the laser head and the RF power module are the responsibility of and must be supplied by the user. A schematic of the recommended configuration of the cooling system is shown in Figure 3-2.

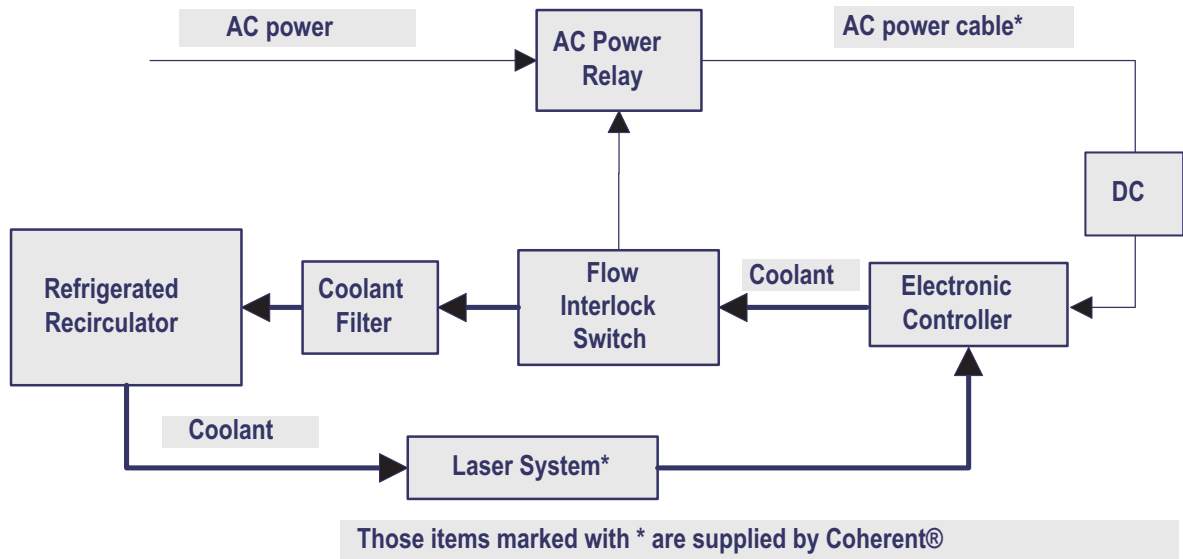

Figure 3-2. Recommended Liquid Cooling System Functional Block Diagram

Cooling System Layout

By connecting the laser head and the RF power module in series, a single interlock will protect the laser system.

Following the flow of coolant from the refrigerated recirculator, the laser head is the first element reached by the coolant after it leaves the recirculator. This assures that the laser head receives the lowest temperature coolant available.

To prevent inadvertent operation of the laser without adequate coolant, an interlock must be provided such that laser operation is prevented, unless coolant is provided that meets the requirements indicated in Table 1-2.

Re-Circulation and Coolant Flow Interlock Switch

The coolant flow interlock switch should be the last element traversed by the coolant before it returns to the coolant filter in the return line. This assures that the flow switch verifies that coolant is flowing through the laser system. The flow switch must not be placed in any other position. The interlock, which is tripped when the coolant switch indicates no flow or low flow, cuts off AC power to the RF power module to prevent the system from overheating.

Signal Interface

The signal interface in the laser interlock system may be used to turn the laser off when the coolant interlock is breached. With this approach, the laser is commanded to shut down via the signal interface, in the event that the coolant interlock system detects a coolant fault. Coherent recommends that both RF Enable and Control Enable be commanded to the OFF state when the coolant interlock system detects a coolant fault. These signals are listed in Table 4-1 and described in subsections of Section Four: Laser Operation.

Thermal Shutdown Switch

The DIAMOND C-40 has a thermal protection switch that protects the system at case temperatures over 80°C. Coherent recommends, however, that the OEM install sensors that detect coolant flow and shuts the laser down in the event of loss of coolant.

The system also provides a high temperature warning. This warning is used to alert the user to the need of maintenance in order to return the cooling system performance back to normal, full cooling capacity. Failure to take action regarding the temperature warning will result in poorer product performance (outside specifications) and lesser product life time.

DC Power Relay

The recommended DC power relay used to cut DC power to the laser off in the event of cooling system failure can also be used as part of the laser safety interlock system. Similarly, if the signal interface is used to shut down the laser when there is a cooling system fault, the signal interface can be used to shut down the laser in the event that there is a breach of a safety interlock. The design of the interlock controls must be in compliance with applicable safety standards, including those described in Section Two: Laser Safety.

Condensation of Water Vapor

If the coolant temperature is below the dew point of the ambient air, water will condense out of the air onto the outside of the laser head, and onto the outside surface and internal surfaces of the RF power module. Condensation can damage the output optical element of the laser head when the laser is turned on, and could damage internal components of the RF power module if power is applied while condensate is present.



NOTICE!

To avoid damaging the system, never allow the coolant temperature to fall below the dew point of the ambient air. Turn the coolant flow off if the laser will be off or stored for an extended period of time in humid conditions.

If necessary, the laser system can operate with coolant temperatures slightly below the dew point of the ambient air. This requires special procedures to be followed, such as shutting off the coolant flow at all times when the laser is not producing laser output. Contact Coherent Customer Service for more information about this option before attempting to operate the system in ambient air below the dew point.



NOTICE!

To avoid possible damage to the laser head, never attempt to change the coolant fittings at the locations where the coolant enters the laser head. If the fittings must be changed for any reason, return the laser head to Coherent to be serviced by Coherent technicians.

Coolant Fittings on Laser System

The DIAMOND C-40 liquid cooled laser has 6 mm O.D. tubing for the connection interface. The user must supply an appropriate compression fitting to make the connection with the rest of the user's system.

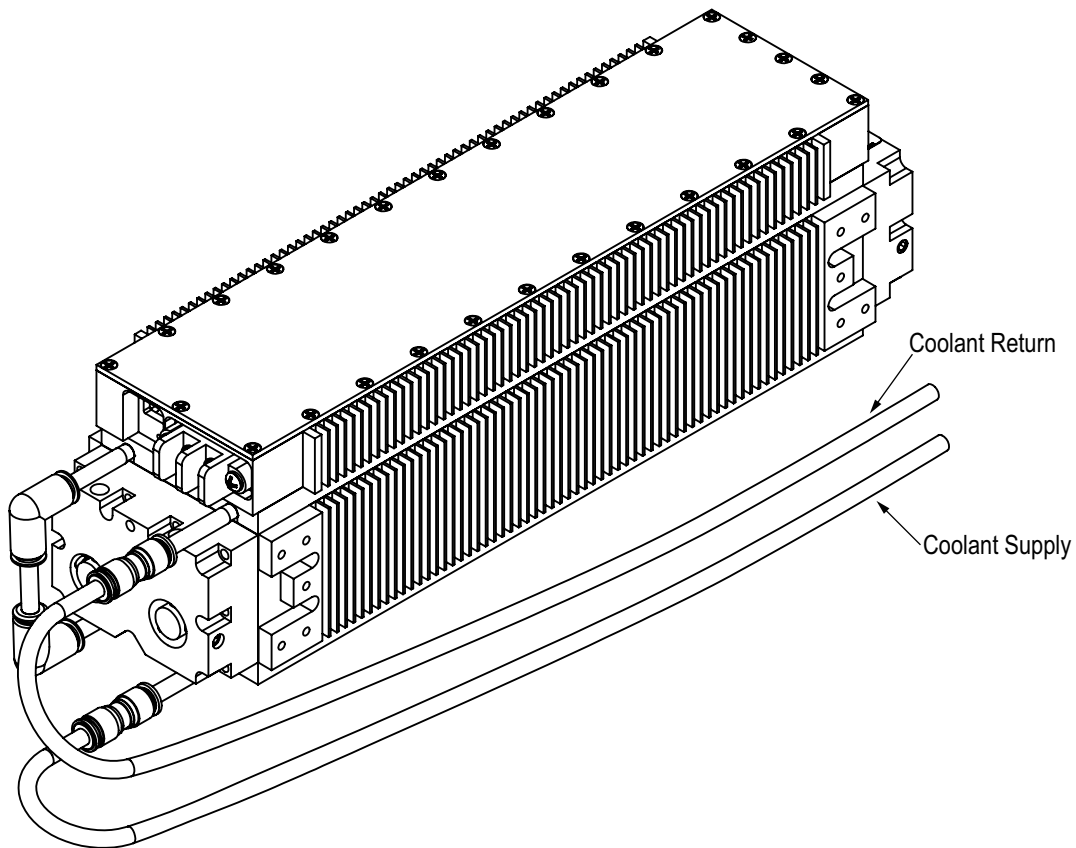

Figure 3-3. DIAMOND C-40 Liquid Cooling Connections

Cooling Capacity

The cooling system must have sufficient capacity to maintain the coolant temperature at the outlet of the refrigerated recirculator within the range given in Table 1-2 on page 1-5. With the laser operating at its maximum output power, the cooling system must dissipate up to 695 W. See Section Five: Maintenance and Troubleshooting for maintenance and replacement requirements for the coolant.

Coolant Filtering

Coherent recommends that the user incorporate coolant filtering in the coolant return line to avoid the accumulation of debris in the cooling system, as shown in Figure 3-2. The filter should trap particles larger than 30 μm to 50 μm in size, unless specified otherwise by the manufacturer of the refrigerated recirculator.

Coolant Flow Rate and Pressure

Requirements on coolant flow rate are listed in Table 1-2 on page 1-5. To prevent damage to the laser head or the RF power module, the gauge pressure of the coolant at the laser head and at the RF power module must not exceed 100 psig (i.e. the gauge pressure – the difference between the absolute pressure of the coolant and the absolute pressure of the ambient air – must not exceed 7 kg/cm^2 , or 690 kPa). Note that the gauge pressure at the laser system includes the effect of the gravitational pressure change if the refrigerated recirculator is mounted much higher than the laser system.



NOTICE!

Exceeding the maximum allowed gauge pressure in the laser head or RF power module, even for a short period of time, may cause irreversible damage and result in permanent coolant leaks.

Depending on the customer's overall cooling system design, portions of the cooling system, other than the laser head and the RF power module, may limit the maximum-allowed gauge pressure of the coolant to a lower pressure than the value noted above for the laser head and the RF power module.

Pressure Drop

The pressure drop from the coolant outlet to the coolant inlet of the refrigerated recirculator will depend on many factors, including:

- Flow rate
- Temperature
- Length and inside diameter of coolant hoses and connections
- Coolant composition

To achieve the minimum flow rates listed in Table 1-2 on page 1-5, provide a pressure drop of no more than 22 psi (1.55 kg/cm^2) between coolant inlet and coolant outlet of the laser. In addition, there is some pressure drop in the cooling lines, which depends primarily on the diameter and length of these lines.

Electrical Power Connection

The DIAMOND C-40 laser requires 48 VDC input DC power. This power is carried from the power source to the system through the terminal block on the DIAMOND C-40. The maximum current required is 13 A (20 A peak for minimum of 1 ms).

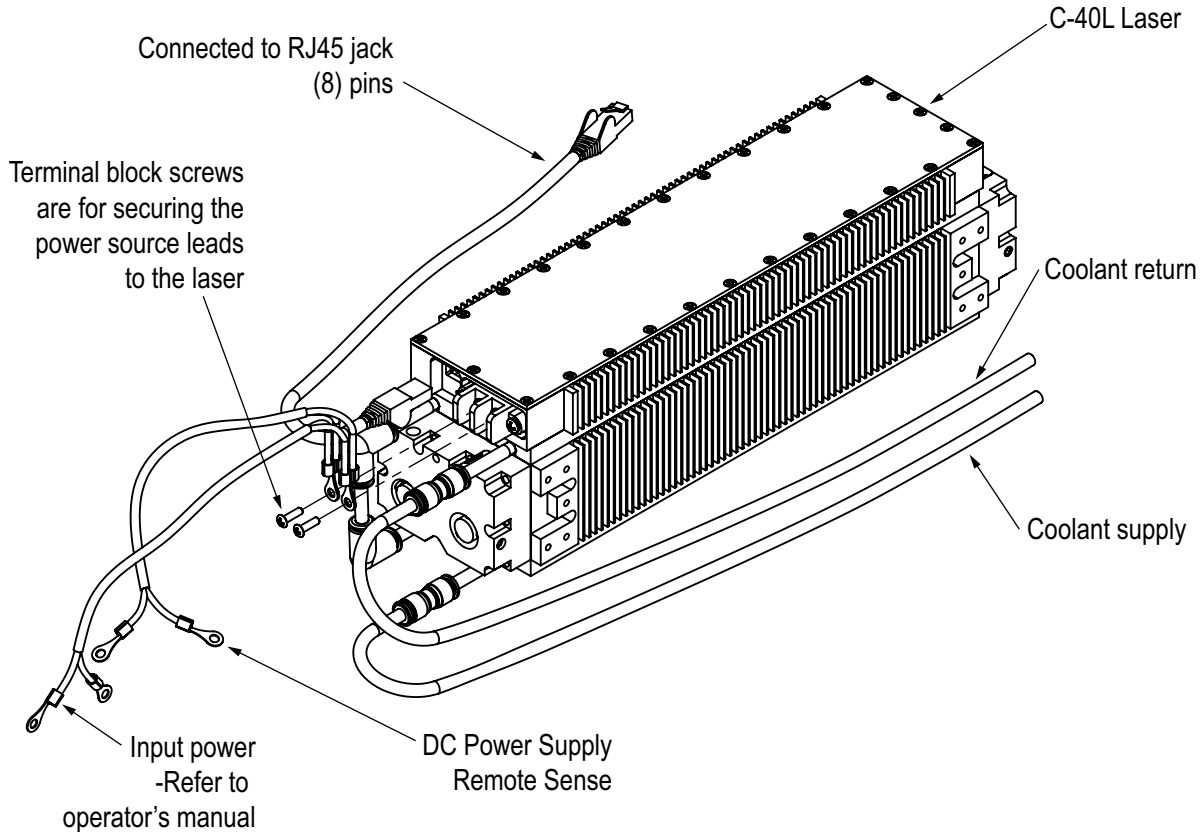

Note: Pin #1 of RJ45 control interface is on the left as viewed.

NOTICE!

To avoid damage to the system, connect leads to the user-supplied power source last after other connection are made.

Figure 3-4. Electrical Connections to DIAMOND C-40

The negative (return) side of the DC input connection to the DIAMOND C-40 RF power module is connected internally to the chassis. The user must assure that the system into which the DIAMOND C-40 is built protects any personnel against the possibility that the DIAMOND C-40 chassis could contain a hazardous voltage and be exposed to these voltages.



DANGER!

To avoid potentially fatal electrical shock hazards from electrical equipment, be sure to follow all applicable electrical codes, such as (in the U.S.) the National Electrical Code.

Coherent strongly recommends that the user review the precautions described in Section Two: Laser Safety regarding electrical safety before using the DIAMOND C-40 laser. It is the user's responsibility to provide circuit breakers and/or fusing of the AC power source, in accordance with all applicable laws and regulations.

DC Power Supply Requirements

Requirements for the customer-supplied DC power supplies include standards regarding DC power supply cabling and over-voltage tripping.

DC Voltage	48 VDC measured at the terminals.
Peak Current	20 A for a minimum of 1 ms with a maximum voltage drop of 1.5 V
Regulation	< ± 2%
Regulation Sensing	Remote at load
Ripple and Noise	< 1% p-p (20 MHz BW limit)
Overload Protect	Automatic Recovery
ShortCircuit Protect	Automatic Recovery

DC Power Supply Cabling Requirements

Coherent strongly recommends the use of remote voltage sense/regulation at the DIAMOND C-40. This requires a 4-wire cable (2 supply currents and 2 voltage senses).

The following requirement minimizes the voltage loss from the supply to the DIAMOND C-40:

WIRE LENGTH (IN METERS)	AWG
0-2	18
2-3	16
3-5	14
5-8	12
8-12	10
12-20	8

DC Power Supply Over-Voltage Tripping

In the event that the DC power supply trips because of the current, there are two countermeasures that can be applied:

- Remote sensing, in which four wires are used to sense the regulation of the DC power supply
- Increased capacitance at the laser connection; to do this, add a capacitor at the DC power supply connection of the laser, using a capacitor of 470 μ F or greater, rated at > 60 VDC

Control Signal Connection

Electrical control of the DIAMOND C-40 laser is achieved via a RJ-45 connector built into the system. The signals carried on each of the pins are indicated in Table 4-1. Details about controlling the laser through the signal interface are discussed in Section Four: Laser Operation.



NOTICE!

Coherent highly recommends use of shielded interface cables. The interface cable shield must connect to the chassis ground of the controller. In addition to proper shielding, this shield provides a secondary connection for the signal ground (Pin 8).

A floating ground connection (use of un-shielded interface cable or no return path between the host control electronics and the laser) can present an unsafe condition and result in unstable or unexpected operation of the laser. This condition can arise when the control signal ground connection (Pin 8) is lost and the Control Enable (Pin 7) and RF Enable (Pin 1) remain high. Therefore, Coherent strongly recommends that a second safety ground be provided either via a shielded control cable or common potential chassis mounting between the laser head and the control electronics. Inadequate or nonexistent grounding between the laser and the external control system can result in loss of control of the laser and damage to the laser electronics or the external control electronics.

Beam Propagation

The DIAMOND C-40 delivers a 3.6 mm $1/e^2$ diameter beam with a 5.0 mrad $1/e^2$ full angle divergence. The typical beam diameter as a function of distance from the laser is shown in Figure 3-5.

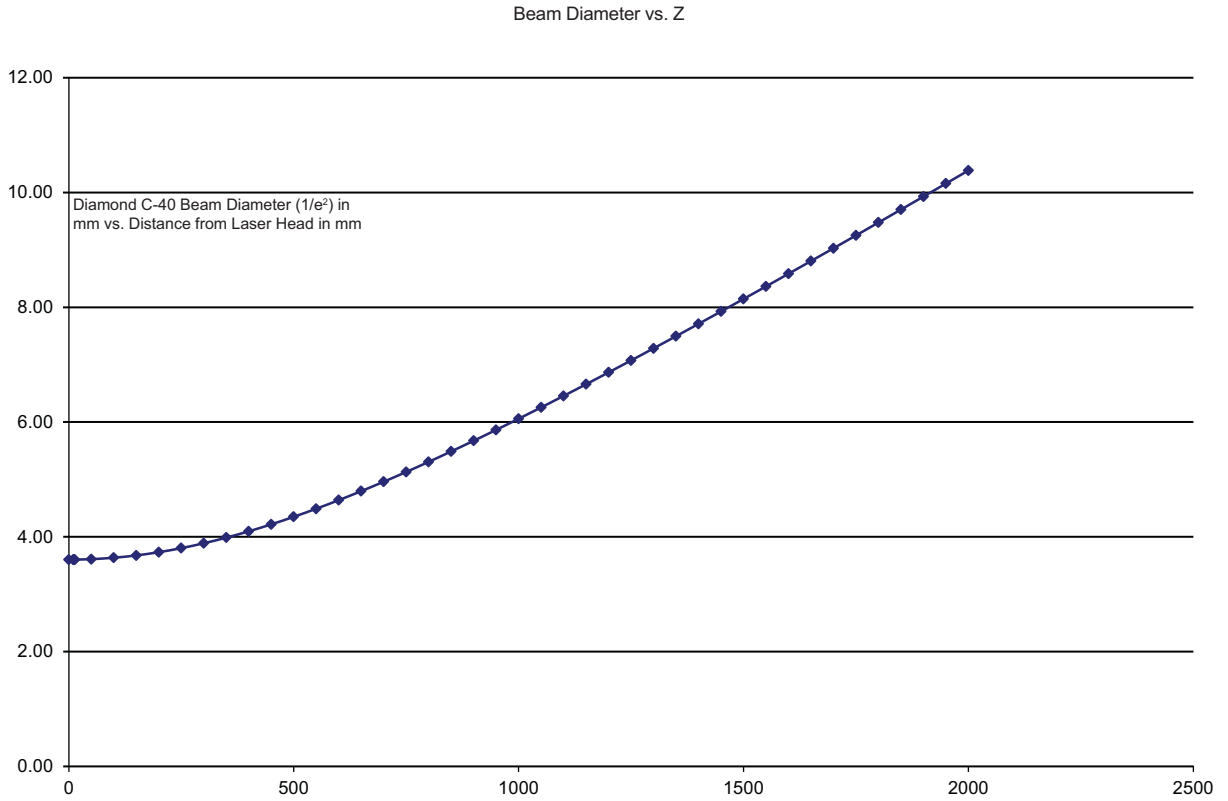

Figure 3-5. Beam Diameter vs. Distance from Laser Head

